



**TECHNICAL DESCRIPTION
OF A
SONIC
ANEMOMETER/THERMOMETER**

(Rev. G)

Prepared by:

**Applied Technologies, Inc.
952 S. Sherman Drive
Longmont, Colorado 80501
PHONE: 303/684-8722
FAX: 303/684-8773**

GENERAL

The Sonic Anemometer/Thermometer is a microcomputer-based wind sensor capable of measuring wind velocities in one, two, or three axes with reliable accuracy. The instrument is designed to measure wind velocity components by transmitting and receiving sonic signals along the fixed orthogonal directions. The microcomputer electronics then processes this information and calculates the wind velocity in each axis. The sonic offers several major advantages over cup anemometers and bivan systems. Since there are no moving parts to come into dynamic equilibrium with the airflow, the sonic responds rapidly to wind velocity fluctuations. It responds linearly to wind velocity and is free from contamination from other velocity components as well as pressure, temperature, and relative humidity. The calibration of the sensor is established by its design parameters and, therefore, can be used as an absolute instrument.

The probe array was designed to minimize flow distortion created by the supporting base, and to permit a very wide, approximately 300 degrees, unobstructed coverage of the velocity components. The array may be oriented in any direction, but ideally, the probe should be mounted upwind of any supporting structure or tower. The transducers are piezoelectric crystals and are completely sealed for rugged outdoor operation.

The temperature information is the sonic temperature of the measured winds and is calculated from the vertical sonic measurements.

The electronics are all contained in the probe assembly. This allows it to be operated as a tower mounted instrument, capable of withstanding hostile environmental conditions. The transducer operation and sonic functions, as well as all the computation and transmission of data are under microprocessor control.

Data from the Sonic Anemometer/Thermometer are digital in nature. The output is RS-232C compatible in a UART asynchronous format and represents the data in ASCII decimal numbers. The output may be connected directly to a computer, transmitted to any digital recording device, or the format is such that it can also be read directly on a terminal.

The Sonic Anemometer/Thermometer represents a state-of-the-art application of a proven measurement technology. Performance over an extended temperature range, and under hostile environmental conditions, provides the user with a low power, DC instrument that will operate reliably and unattended.

SYSTEM DESCRIPTION

The Sonic Anemometer/Thermometer manufactured by Applied Technologies, Inc. is a model SAT1/3(X), where [X] represents the style of probe array. The system consists of two (2) elements as illustrated. These are as follows:

- Probe Assembly with electronics
- Mounting Arm

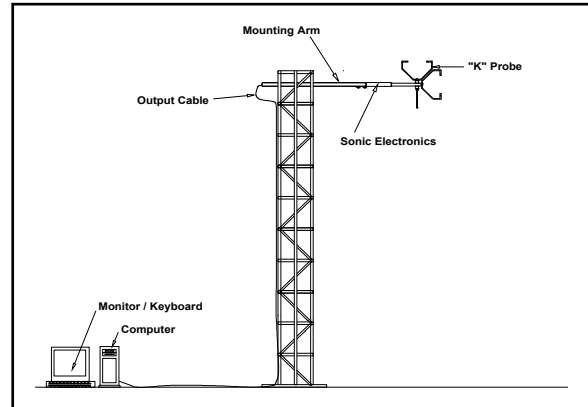

PARTS

The Sonic Anemometer/Thermometer is supplied with the following parts at no extra cost: all mating cable connectors, the mounting bar, and a zero air chamber for calibration.

FEATURES

The features of the Sonic Anemometer/Thermometer are as follows:

- Single component wind velocity
- Fast response temperature
- Extreme accuracy
- Microprocessor-based
- Solid-state digital operation
- No moving parts
- Unattended operation
- Ease of mounting
- Rugged construction
- Low power
- DC powered

FUNCTIONS

The Sonic Anemometer/Thermometer has many software configurable functions, making it a very flexible instrument.

The functions incorporated into the Sonic Anemometer/Thermometer include:

- Ability to do remote commands through the serial port
- Perform internal calibration to maintain accuracy
- User programmable sample rates and averaging, from 5min to 200Hz
- Exchange averaging with median filter
- User adjustable data output rates
- Select from several output formats
- Select from several baud rates
- Synchronize sonic operation to external trigger
- Ability to output a trigger pulse for other instruments
- Select the output Speed of Sound and/or Temperature
- Enter RH value for more accurate temperature output
- User adjustments to temperature calculations
- Change horizontal velocity to wind speed & direction, while retaining vertical and temp.
- Select data quality algorithm (to remove spikes)
- User adjustments to data quality calculations
- Ability to provide data quality status word in output format
- Turn flow distortion correction on/or/off
- User adjustment to flow distortion calculations

These functions are accessed by software commands via the serial port.

PROBE ASSEMBLY

Five styles of probe design are available depending on the individual requirements of the application. They are as follows:

- **“V” Style Probe Assembly** – *a special design for turbulence, where eddy measurements must be the smallest.*
- **“Vx” Style Probe Assembly** – *a compact design for flux measurements in plant and forest canopies where wind speeds are very low and directions highly unpredictable*
- **“K” Style Probe Assembly** – *ideal for atmospheric boundary layer studies. It’s suited for a variety of applications. This design minimizes flow distortion.*
- **“Sx” Style Probe Assembly** – *ideal for environmental monitoring applications where horizontal wind measurements are required to be in the same plane.*

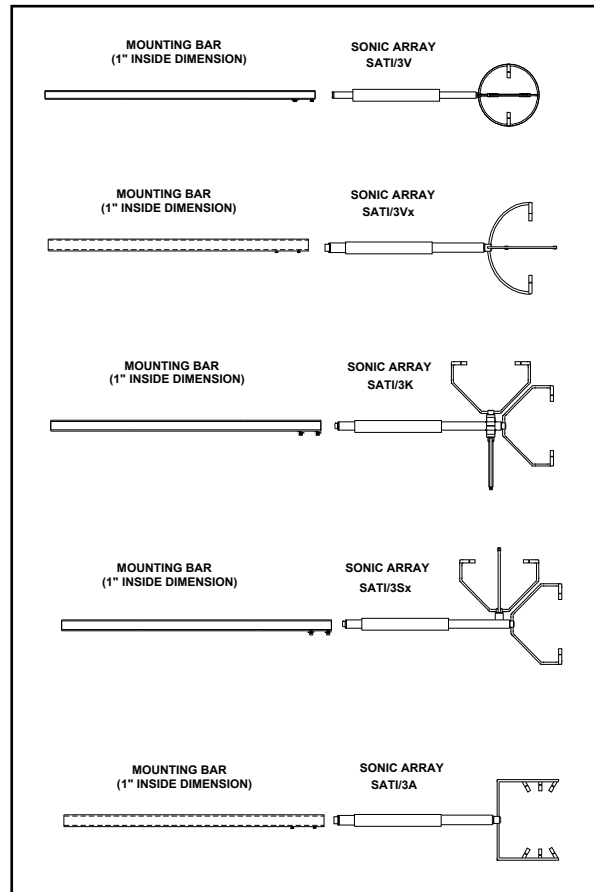

- **“A” Style Probe Assembly** - *non-orthogonal design ideal for higher wind speeds.*

The "Sx" style probe is also available in a one or two axis array. The "K", "V", "Vx" and "A" style probes are strictly three axis probes. All probes are constructed of solid aluminum arms, sufficiently small enough to minimize any cross-sectional area exposed to the wind flow being measured. A transducer is mounted on the end of each arm. These transducers operate in both a transmit and receive mode.

The probe array is permanently fixed and does not require an alignment jig. The orthogonality and alignment accuracy of the probe and transducers is better than 0.1°, and the supporting base structure is designed with a flat surface for accurate leveling. The array orientation is designed to provide approximately 300 degrees of unobstructed exposure to the wind.

The probe array design of the ATI Sonic Anemometer/Thermometer provides a true vertical velocity measurement on the four basic probes. The *W* component is not inferred nor calculated from some other measurement, but is a direct measurement that has alignment accuracy to within ±0.1°.

FLOW DISTORTION

“K” Style Probe:

This probe was designed to minimize probe-induced flow distortion errors in a 3-axis sonic anemometer. By separating the three axes, mutual interference between the transducers and supports of the three components is reduced to a negligible level. This sonic probe requires only a straightforward transducer shadow correction to obtain measurements that are virtually insensitive to probe orientation relative to the mean flow. Tests have demonstrated that there are no biases, wind speed dependencies, or wakes from adjacent axes to account for.

The vertical separation in the horizontal axes imposes a minimum limit on the height at which this probe can be operated with confidence. Tests and observations have demonstrated that 10 meters and above is a good rule of thumb.

“Vx” and “V” Style Probes:

These probes were designed for turbulent wind measurements in a forest or other plant canopy. Because of the interrelation of the three components, these probes have no minimum height limit. This permits use of these probes for measurements from ground level to about 1 or 2 meters above the ground.

In these environments, the probes work very well, but these probes will NOT measure laminar air movements. These probes cannot be used in a wind tunnel or for boundary layer type measurements.

“Sx” Style Probe:

This probe was designed to fulfill the gap between the height ranges of the two styles above. Because of the combined horizontal axes, it can be used closer to the ground than the “K” style, but still has the W component out front and unobstructed. This separation does impose a minimum height (about 2 meters) but it can be used to measure laminar air if necessary. There will be a slight flow distortion around the horizontal arms, but this too is minimized by the offset of the V component. The only distortion will be at the 90° directions caused by the V component arms.

"A" Style Probe:

This probe design is of the non-orthogonal orientation which moves the transducers out of the measured air flow and minimizes any flow distortion that is caused by the transducers. Because of the transducer orientation, this probe can be used for much higher wind velocity measurements, but the

three components of wind speed are calculated and inferred, and not directly measured.

If the calculated and inferred data is acceptable, this probe can be used over the complete range of measurement heights above the ground.

Transducer Shadowing Correction:

Real-time correction for the transducer shadowing is incorporated in the data handling software. This is performed on all axes of each probe and on all orthogonal probe styles.

MOUNTING ARM

The probe array and structure are designed with every effort directed toward minimizing any mounting obstruction to the wind measurement. The base of the probe is square and designed to attach easily to the mounting arm.

The mounting arm is a square tube, approximately 32" long, and has two captive bolts used to secure the probe. The tubing has an inside opening of 1" with an outside dimension of 1.25".

The probes and mounting arms both have a clear anodized finish for protection from the elements, eliminating the problems associated with paint.

ELECTRONICS

The electronics are located in the probe array. The electronics assembly contains all the circuitry and components necessary for the operation of the Sonic Anemometer/Thermometer and provides the functions shown in the following block diagram.

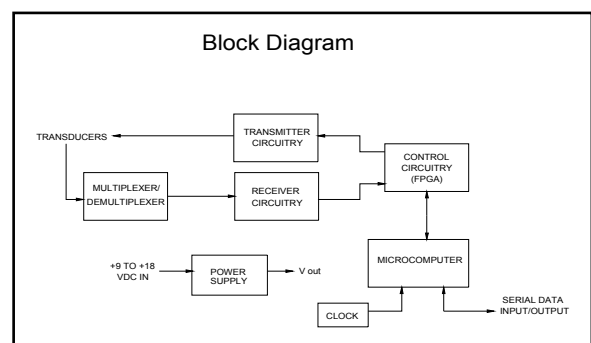

The basic system is DC powered (+9 to +18 VDC). Other power requirements can be accommodated, such as: 110 VAC/60Hz for North American applications, or 220 VAC/50Hz for International applications. (See Options List)

OPERATION

The Sonic Anemometer/Thermometer uses a pulse transmission technique with a transducer pair in each measurement axis. A sonic pulse is generated at one of the transducers and received by the opposing transducer.

Transducers are then multiplexed so that the functions are reversed. Measurements of the transducers are sequenced over a fixed time and a block of these measurements are averaged together to provide an output. This provides anti-aliasing for the data. Calculations derived with these measurements are used to compute wind velocity in each of the corresponding axes and this sample is then the output.

The instrument is a microcomputer-based, digital electronic measurement system. It performs computations on the value of the transit time of the sonic pulse between the transmitter and receiver transducers.

A classic equation is used to solve for the wind velocities in each axis, using the values collected during the transmissions. Using the computed values of wind velocities in each axis, the microcomputer can also trigonometrically compute the vector direction and total speed of the incoming wind.

A separate equation is used to compute the speed of sound of the air medium from these same collected values of transit time. This value is then substituted into the ideal gas equation and solved for the sonic temperature. The final value is corrected for any contamination that may be caused by crosswind components.

The sonic temperature output provided by the instrument is similar to virtual temperature. It will differ from the absolute by an amount proportional to the water vapor content of the measured air. The temperature output may be left as virtual or may be adjusted to provide a more accurate absolute value.

Several variations in output data, format, and timing are a regular part of the instrument operation. One of these is the ability to synchronize the anemometer data taking cycle by use of an "External Trigger". These functions are all software programmable.

The standard output data format consists of words seven ASCII characters long made up of one ID character, a space character that is also used as a polarity sign, and four data characters with decimal point. The data characters can be read directly in engineering terms, however this format may be changed by software commands.

The following table shows the pin-out of the Sonic Anemometer connector:

<u>Pin#</u>	<u>Function</u>	<u>Description</u>
<i>Pin 1</i>	<i>Chassis Ground</i>	<i>Chassis Ground</i>
<i>Pin 2</i>	<i>Spare</i>	<i>N/C</i>
<i>Pin 3</i>	<i>Trigger Output</i>	<i>RS-232 Signal – (+12 to –12 V High to Low)</i>
<i>Pin 4</i>	<i>Spare</i>	<i>N/C</i>
<i>Pin 5</i>	<i>Trigger Input</i>	<i>RS-232 Signal – (+12 to –12 V High to Low)</i>
<i>Pin 6</i>	<i>Ground</i>	<i>GROUND</i>
<i>Pin 7</i>	<i>Ground</i>	<i>GROUND – (RS-232 Common)</i>
<i>Pin 8</i>	<i>Receive Signal</i>	<i>RS-232 Signal – Connects to Transmit Out of computer</i>
<i>Pin 9</i>	<i>Transmit Signal</i>	<i>RS-232 Signal – Connects to Receive In of computer</i>
<i>Pin 10</i>	<i>External Reset</i>	<i>Floats high and requires Grounding to perform Reset</i>
<i>Pin 11</i>	<i>Known State</i>	<i>Floats High, requires Grounding AND the External reset or powered-up.</i>
<i>Pin 12</i>	<i>Vcc Input</i>	<i>+9 to +18 VDC @ 1.2 Watts</i>
<i>Pin 13</i>	<i>Ground</i>	<i>GROUND – (Vcc Return)</i>

CALIBRATION

To perform a calibration of The Sonic Anemometer/Thermometer, install the supplied "Zero-Air Chamber" on the axis to be calibrated (the "V" style probe "Zero-Air Chamber" covers all axes simultaneously).

Calibration of the Sonic Anemometer/Thermometer is done by way of the serial communications. The operator is prompted for temperature information that must be entered for the calibration to be accurate. A measurement of the ambient temperature should be performed to at least 1.0° C or better. The more accurate the temperature, the better the calibration. Commands to enter relative humidity information, which adds to the accuracy of the resultant temperature, are also available.

The microcomputer takes a little time to automatically calibrate the Sonic Anemometer/Thermometer, compensate for any electronic drift, and store the new parameters. Upon exiting the calibration mode, the Sonic Anemometer/Thermometer will immediately start outputting data on the data line.

An automatic restart capability has been incorporated into the instrument design in the event of power interruption. All the calibration data are stored in nondestructive memory so when power is restored, the unit starts up again where it left off. This also allows a calibration to be performed on the workbench, so that the instrument can be turned off while it is being moved outdoors.

OPTIONS

- **OUTPUT CABLE**
Factory made and tested output cable of 10m is provided with the instrument. Longer cables may be ordered. (Length must be defined with order)
- **AC POWER SUPPLY**
AC power supply that can be housed in either a desktop enclosure, or a weatherproof enclosure. Both come with an output cable. (Length must be defined with order)
- **A/D CONVERTER INTERFACE**
Is a small weatherproof enclosure mounted close to the sonic and allows for a number of analog inputs to be digitized and added to the sonic data string. Differential inputs are available.
- **RS-422**
The normal RS-232C output can be changed to RS-422 for longer transmissions.
- **WIRELESS COMMUNICATIONS**
This option may be added when long digital lines are not practical. The digital output may be transmitted up to 10 miles or more, line-of-sight.
- **MULTI-SENSOR INTERFACE**
This option provides for the collection of data from multiple sonics and will collect, format, and compact data into a single output.

SPECIAL DESIGNS

Applied Technologies Inc., being a research and development company, has the technical expertise to provide a wide variety of special designs to the customer when ordering the Sonic Anemometer/Thermometer. The following list contains a few concepts that may be of interest:

- Customized mounts for different applications
- Variations in electronic packaging
- External digital inputs
- Provide data in any engineering units
- Special output interfaces for modems, radios, and satellite links
- Output displays for data
- Variations of data storage and averaging of data
- Probe protection from severe icing conditions
- Internal calendar clock time tags
- Extended operating temperature range
- Input of offset heading as a variable

Should a special application require a change or variation not listed here, please feel free to consult with an Applied Technologies, Inc. representative about the design and development of a system to fit your requirements.

WARRANTY

Applied Technologies, Inc. (ATI) will provide a warranty that all products of its manufacture shall be free from defects in material and workmanship for a period of 24 months (2 year) from the date of shipment. Any product or part thereof not manufactured by ATI shall be warranted by ATI only to the extent warranted to ATI by the original manufacture. This warranty is based upon proper use of the product in accordance with the instructions and directions provided by ATI. This warranty requires the return of faulty equipment at the customer's expense to the ATI facilities in Longmont, Colorado. Products judged by ATI to be defective will be repaired or replaced and returned to the customer at ATI's expense.